

WHAT HAS GONE ON BEFORE

or

"How do I find my way around this ship?"

by Robert W. Gibson

A hale and hearty welcome to all from us here on the staff of *Captain Harlock: Deathshadow Rising*. We know many of you here with us are more familiar with Harlock and his world than others who have just come aboard and we thank all of you for giving us the chance to entertain, amuse, thrill (yes, and even enlighten) you with the adventures of Captain Harlock and the crew of the *Arcadia*. For the benefit of those of you who have never ventured into the worlds created by the Japanese master storyteller Leiji Matsumoto, we have assembled some articles herein which we hope will help introduce you to his creations and also to the stories we here at Eternity Comics have done up to this point which are based on those creations. In addition, we offer a peek at some of the new people and mecha you will be seeing as this mini-series progresses. If you like what you see (or even if you don't), be sure to drop us a line and tell us about it. Address all letters, fan art and so forth to: Skull and Crossnotes, c/o Malibu Graphics Publishing Group, 5321 Sterling Center Drive, Westlake Village, CA 91361. Thanks in advance from Robert, Tim, Chris, Dan and the rest of the gang...



And now, without further blather, a rundown of what has gone on before...

My Youth In Arcadia (feature film)

In the 21st century, Earth and its colony worlds were attacked by the Illumidas, a warlike race who live only for conquest. Despite strong resistance from the Solar Federation Navy, the aliens defeated the outnumbered Earth forces and conquered the planet and all its colony worlds. Chief among the champions of Earth was Captain Harlock of the Solar Federation ship *Deathshadow*, but even the valiant Harlock found he could not defeat the aliens. He was finally forced to surrender his ship to the Illumidas Earth Occupation forces, but not before rendering the *Deathshadow* inoperable by crashing her upon his arrival on Earth.

While enduring the occupation with the rest of the inhabitants of Earth, Harlock met Tochiro, a brilliant engineer and technician, and the two became fast friends. When Harlock's lover, Maya, was killed by the Illumidas for encouraging revolt, he and Tochiro took to the stars in the space battleship *Arcadia* (which Tochiro had built in secret) and, together with the free space trader *Emeraldas*, Harlock swore to live under no rule save those laid down by his own conscience. Now,

"Doc" Malone - Arcadia's nurse. Because of her sympathetic ear and commonsense, most on the ship bring their problems to her.

Broygerd - Arcadia's chief Engineer. Tochio's right hand man, he knows more about the ship than anyone but Tochio and Harlock, and takes Tochio's position on the bridge when he is indisposed.

Kei Yuki - Arcadia's navigator. When her father was killed by the Illumidas, she was raised by her "uncle" Daquin and aided him in the rebel cause against the Illumidas. She has a fiery personality.

Harlock - A former Solar Federation Captain, Harlock now fights for only the cause he believes in and goes only where his conscience leads him. He still bears the scars (both inside and out) of his tattered past and carries the memories and insights of many lifetimes wherever he ventures in his mighty battleship, Arcadia. There are few in known space who do not know and fear the Space Pirate Captain Harlock.

Emeraldas - The infamous "Pirate Queen" is almost as feared as Harlock among the Illumidas. She was originally a free space trader and still conducts business in parts of the galaxy, but feels just as Harlock does on most important matters. Her ship, the Queen Emeraldas, is manned totally by robots, helping to reinforce her reputation as a cold, unfeeling, solitary person (a reputation she does little to rid herself of).

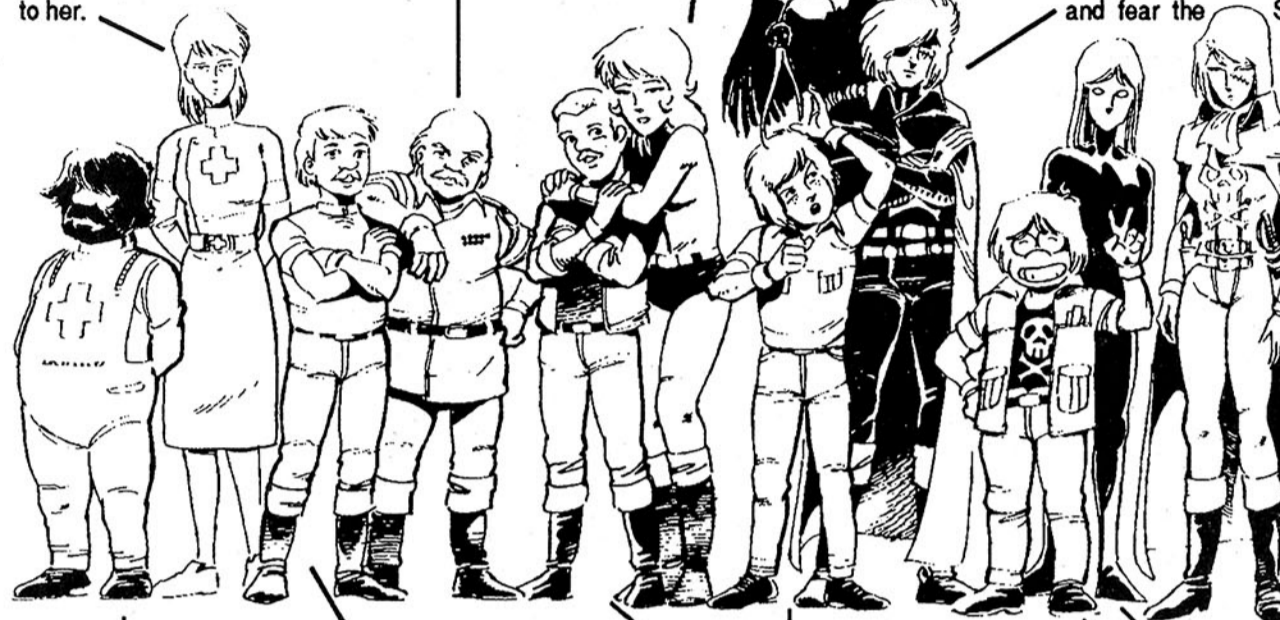

Dr. Zero - Arcadia's doctor. He is usually a very rational man, but is driven to drink excessively because of the events of his past.

Sufrin - Chief warp technician. Very easy-going, he's everyone's best friend and always has useful advice to give on everything from stabilizers to self-esteem.

Tadashi - His father sacrificed himself to save Harlock's life and the grateful Captain took Tadashi aboard the Arcadia, hoping to eventually find a safe home for him. But Tadashi has found a permanent place as part of the crew of the Arcadia.

La Mime - The only survivor of a dead world, La Mime keeps things running smoothly on the Arcadia and is Harlock's spiritual advisor. She was once privy to the secrets of the Earth Occupation Forces and is a very valuable source of information on the Illumidas.

Daquin - Harlock's ex-navigator on the Deathshadow. Daquin developed radiation poisoning when helping in the rebel uprisings against the Illumidas and knows he does not have long to live.

Tochio Oyama - Harlock's best friend and confidant, Tochio is the best engineer on present Earth and quite possibly the best the planet has ever produced. In addition, his heart is larger than his head (figuratively), which leads him to act irrationally on occasion, but you can always count on him to do the right thing in a tense situation. He designed and built the Arcadia and is, in many ways, its very soul.

aided by a crew who feels as they do, Harlock and Tochio roam the sea of stars as pirates, moving from place to place, living their lives under the flag of freedom...

Space Pirate Captain Harlock Issues #1-3 ("Captain Harlock Returns"). Malibu Graphics

When one of his crewmen is captured by Supreme Commander Muda and the Illumidas Earth Occupation Force and is put on trial for crimes against the people of Earth, Captain Harlock and the Arcadia return to Earth to retrieve him. Before the rescue, a former member of Harlock's crew thwarts an attempt by the Illumidas to kidnap the good Captain, but pays the ultimate price. In payment for the sacrifices, Harlock agrees to take the dead man's son, an Earth boy named Tadashi, away from the capital city to a place where he can grow up in peace.

Harlock attempts to leave Tadashi in the care of his old teacher, Milos, in the land of the pirate's birth, but the Earth official in charge of the region, Darghund, learns of this and confronts the pirate for his own selfish reasons. While the Illumidas desperately try to bombard the region in an attempt to kill the Captain, Harlock and Darghund duel, but they are interrupted by Harlock's teacher, who sacrifices himself in order to stop Darghund from

killing the pirate. Tadashi saves Harlock's life and the latter agrees to let him stay on the Arcadia.

Space Pirate Captain Harlock Issues 4-6 ("Eternal Wanderer Emeraldas"). Malibu Graphics

Harlock and the crew of the Arcadia escape both the Illumidas and Earth's orbit when Tadashi comes through in the pinch and operates the ship's warp manually. Unfortunately, one of the ship's chief technicians is badly injured in the incident and a handicapped member of the crew, Verlong, blames himself. The Arcadia and crew retreat to their SSX base in the asteroid belt and find the Pirate Queen Emeraldas there waiting for them...

While waiting to hear of the status of their injured shipmate, Verlong tells Tadashi of how difficult it was growing up handicapped on occupied Earth. Meanwhile, Emeraldas leaves with cargo bound for Tastasia but interrupts her mission to thwart a hijacking by a rival space pirate, Torian, who has gained possession of the old Solar Federation ship, Dark Victory. Unfortunately, Torian has also gotten his hands on a prototype warp field nullifier and shield system which he uses to keep Emeraldas from warping away. He then sends a false SOS message in attempt to lure Harlock into the same trap...

Baron Darghund - An old rival of Harlock's, he is now one of the leaders of the resistance on occupied Earth.

Alex Nevich - Alexander's son to whom his father shows almost fanatical duty, and the elder Nevich seems to be grooming Alex to be the future leader of free Earth.

Supreme Commander Muda - The leader of the Illumidas Earth Occupation Forces, Muda hates the Pirate Harlock for the many times he has interfered with the smooth running of the occupation and the surrounding sectors. Muda is cold and calculating and not above sacrificing Illumidas lives to achieve his goals.

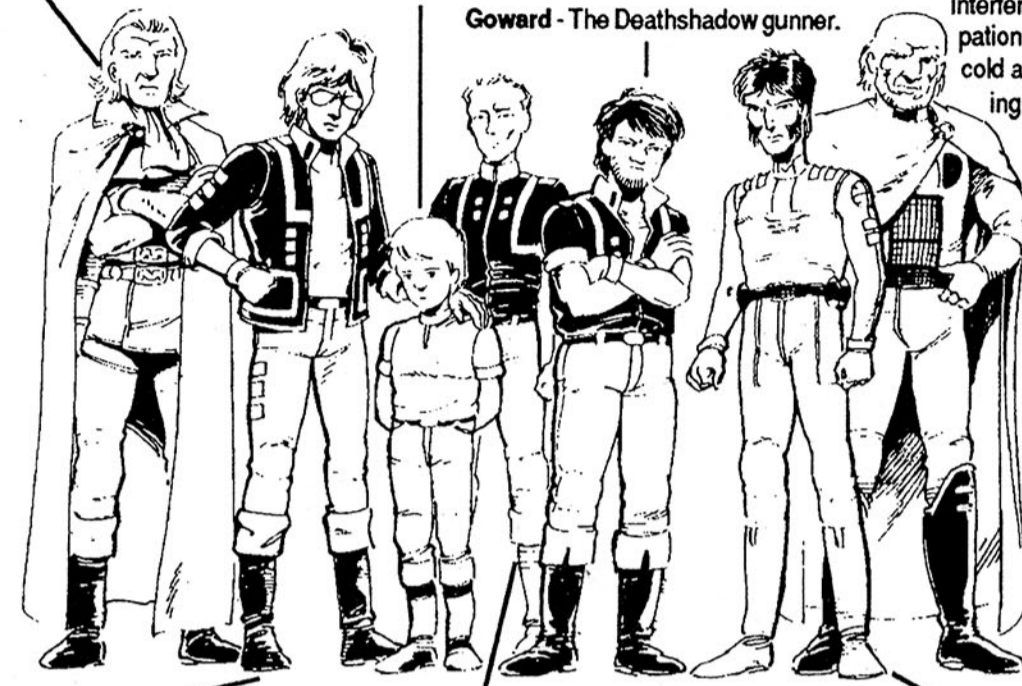

Alexander Nevich - A brilliant engineer, designer and tactician, also a former Solar Federation Commander. Nevich is a mysterious man, and all of his motives are not clear at present. He has entered into an alliance with the Illumidas to track down and destroy Harlock, and to this aim, he has rebuilt the Deathshadow, Harlock's old ship.

Holden - The Deathshadow's helmsman and navigator. Like all of Nevich's men, he is extremely loyal to his commander.

Shadan - Second-in-Command of the Illumidas Earth Occupation Forces and personal advisor to Supreme Commander Muda. It was on his recommendation that Muda agreed to Operation Dreadnaught and thus he was stationed on board the ship to oversee the completion of its mission.

Tochio gets the SOS and takes a lone fighter out to investigate. Meanwhile, Torian and his crew begin to lose control of the field generator and, when Emeraldas presses her attack, they lose control completely and the Dark Victory is warped away to an unknown destination. Back on the SSX base, Verlong learns that sometimes a handicap is not necessarily a handicap and that most miracles are man made.

Space Pirate Captain Harlock Issues #7-10 ("Sins of the Father")

In need of a part for their warp system, the crew of the Arcadia journey to El Dorado, a space colony where indentured servitude is legal. Once there, Tochio and Doctor Zero, who is searching for his son (whom he indentured to send him to a better life), are captured by Estarian, the governor of the colony. Estarian is under pressure from the Illumidas representatives there to turn Tochio over to them. Meanwhile, Tadashi meets the "sons" of Estarian, one of whom turns out to be Zero's missing son and the three are saved from death by a mysterious man named Faust. The Illumidas attack Estarian's estate and capture Tochio.

When Estarian informs Harlock that he no longer is in possession of Tochio, the Captain decides to attack the colony and take his friend back by force. Inspired by Harlock's stand, the people of El Dorado decide to throw the Illumidas off their colony for good and join in the conflict. During the attack, Laru (the Illumidas in charge of the garrison) calls for assistance from the Illumidas fleet and takes Estarian and Tochio hostage in an attempt to escape. The hostages

are freed, but Zero's son and Verlong are badly injured in the fight. Harlock and the crew of the Arcadia help the colonists fight off the Illumidas fleet and Zero joins the crew as the ship's doctor, leaving his son behind in the care of Estarian. Verlong finds out the father he thought was dead has been serving beside him all the time...

Space Pirate Captain Harlock #11-13 ("Message in a Bottle")

Harlock tells a story about his life in the old Solar Federation Navy aboard the Deathshadow during the war with the Illumidas. When the Arcadia receives a distress signal from a rebel outpost, Harlock comes to the rescue, only to find the rebels are being led by Daquin, the Deathshadow's former navigator, and Kei Yuki, a daughter of one of Harlock's old shipmates. Kei's mother is killed in the battle to wrest the outpost away from attacking Illumidas, and Kei and Daquin join the crew of the Arcadia. Kei is appointed the Arcadia's new navigator, but her joy is short lived when she learns that Daquin is dying of radiation poisoning and that there is no known cure. Together, the group returns aboard the Arcadia to the SSX base, somewhere in the asteroid belt.

But throughout the preceding events, the Earth Occupation Forces have not been idle. While Harlock and his crew have been roaming the stars, a sinister alliance has been forged on Earth between Illumidas Supreme Commander Muda and Alexander Nevich, an embittered officer of the old Solar Federation. Together, the two have agreed on a method of ridding the stars of the space pirate once and for all...

SPACE BATTLESHIP ARCADIA

Engineer and designer Oyama Tochiro secretly built this ship of freedom by himself in a disused underground dock under the oppressive Illumidas occupation of Earth, waiting for the day when a worthy captain would appear. Now Harlock and Tochiro wander the stars in this powerful vessel. The body of the Arcadia is heavily reinforced and its firepower is equal to that of an average fleet of warships.

Length: 400m
 Width: 260m
 Height: 158m
 Crew: 41 (1 bird, 1 cat)

Armament: 3 Pulsar Cannons
 1 Pulse missile Launcher with 8 Firing Ports
 6 Torpedo Tubes
 "Space Wolf" Fighter Craft

- | | | |
|-------------------------------------|----------------------------------|-------------------------------|
| 1. Bow Circuit Room | 14. Second Bridge | 27. Secondary Engine Room |
| 2. Communication Control Room | 15. Main Bridge | 28. Main Engine Room |
| 3. Bow Radar Room | 16. Cosmo Radar Dome/Observatory | 29. Recreation Room |
| 4. Torpedo Storage | 17. 3-D Navigational Tank | 30. Stabilizer Wing |
| 5. Energy Control Room | 18. Main Planning Room | 31. Dining/Mess Hall |
| 6. Main Energy Reactor | 19. Data Bank | 32. Sick Bay |
| 7. Bow Energy Generator | 20. Main Computer Room | 33. Operating Room |
| 8. Primary Cannon Firing Control | 21. Radio Telescope | 34. Gunnery Control Room |
| 9. Crew Meeting Room | 22. Captain's Quarters | 35. Hanger Bay |
| 10. Laboratory | 23. Crew Cabins | 36. Fighter Storage |
| 11. Secondary Cannon Firing Control | 24. Liquor Storage | 37. Ammunition Storage/Armory |
| 12. Communications Command Room | 25. Main Engine | 38. Energy Tank |
| 13. Third Bridge | 26. Solar Battery | 39. Cosmos Sonar |

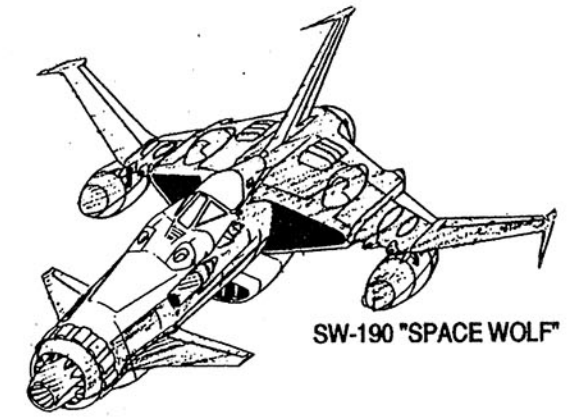
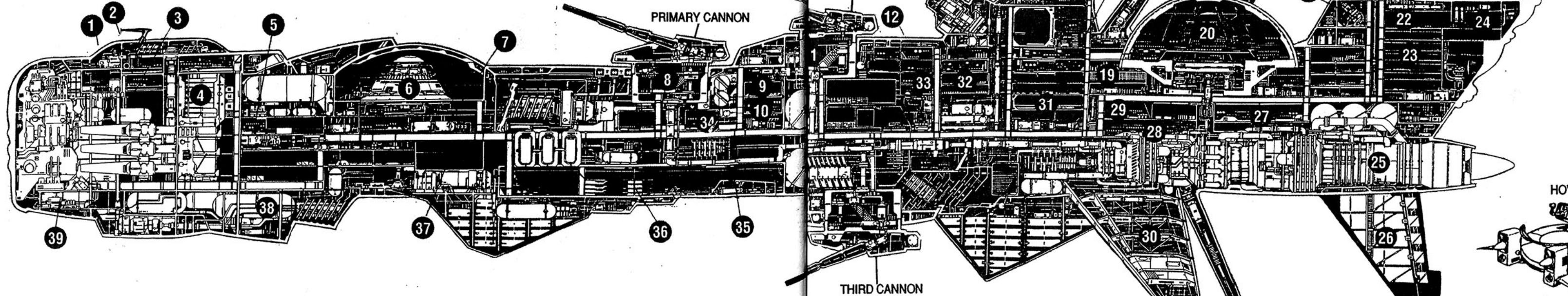

SW-190 "SPACE WOLF"

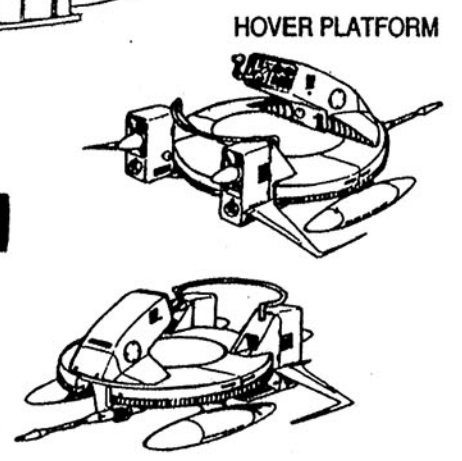

HOVER PLATFORM

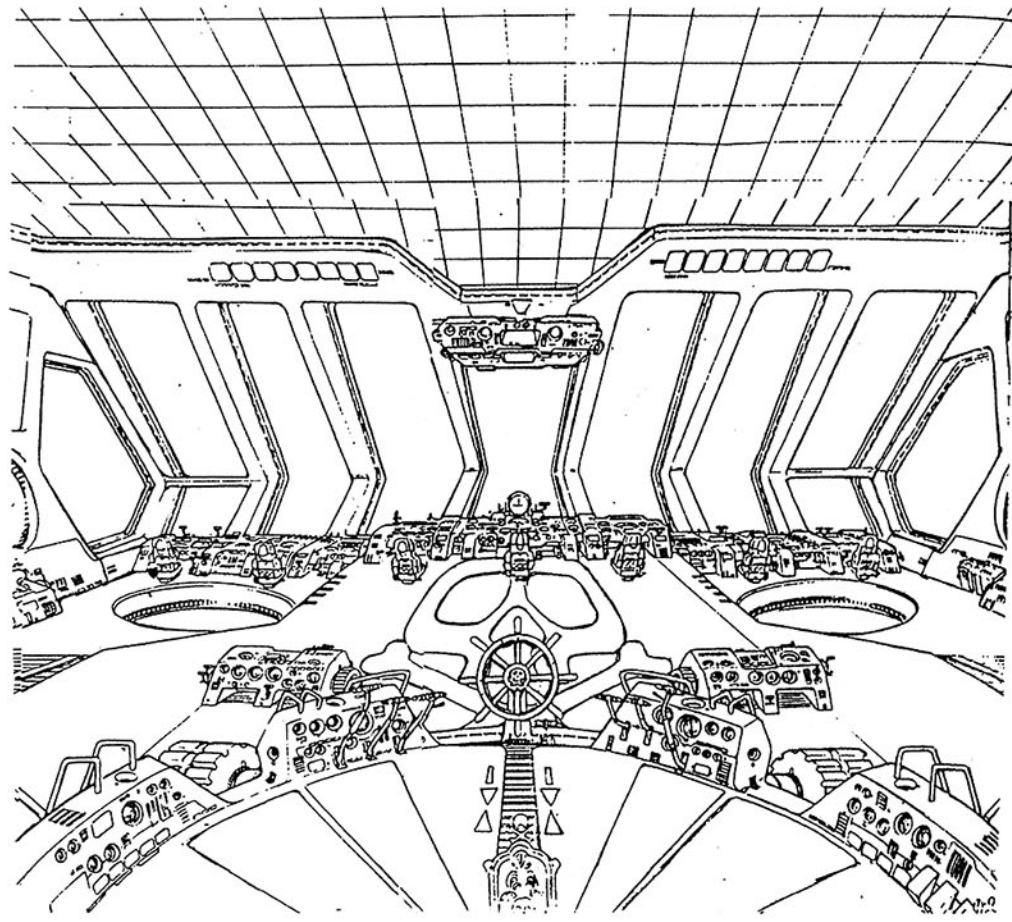

BRIDGE DETAIL

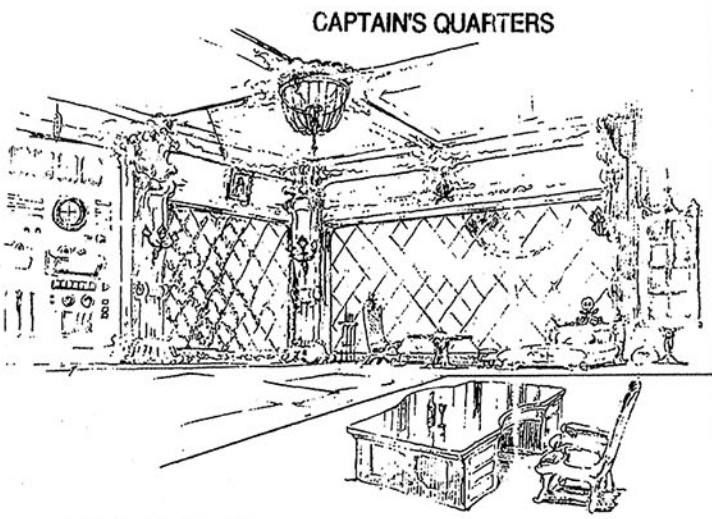

CAPTAIN'S QUARTERS

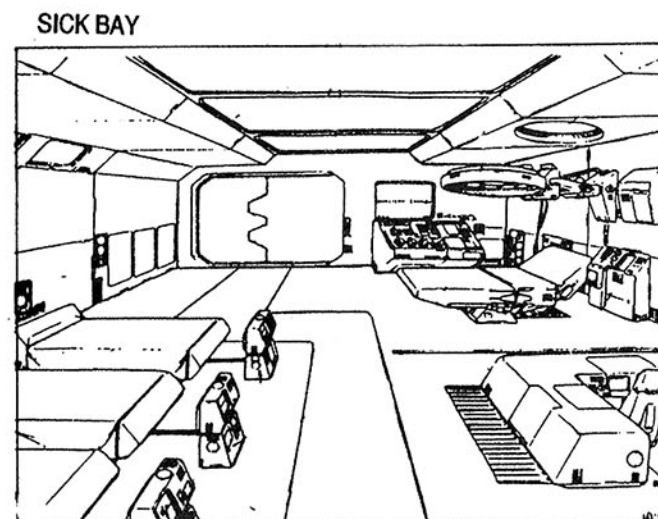

SICK BAY

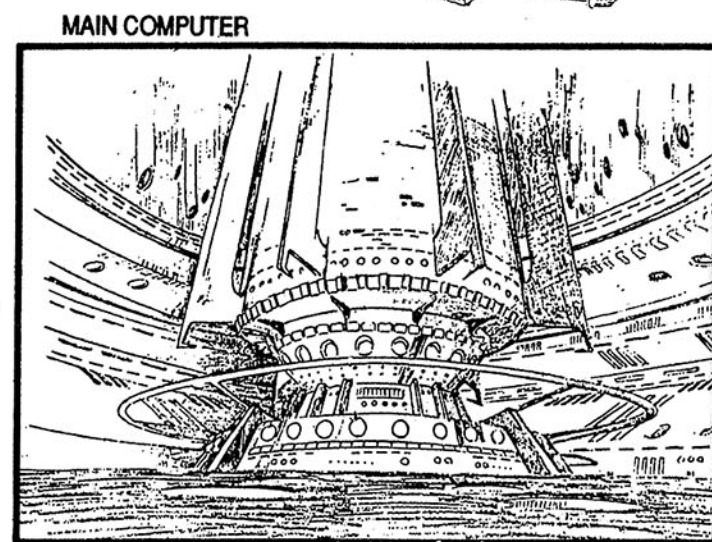

MAIN COMPUTER

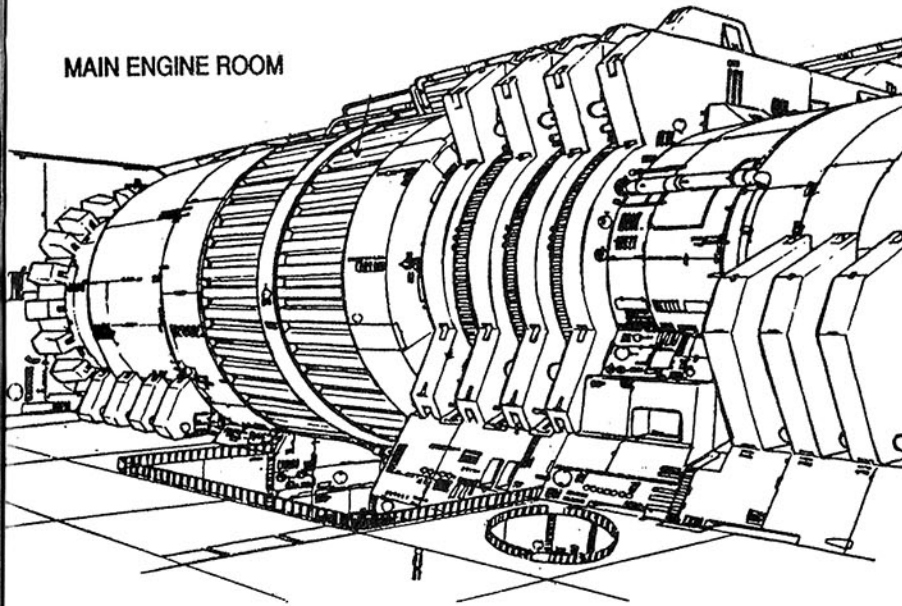

MAIN ENGINE ROOM

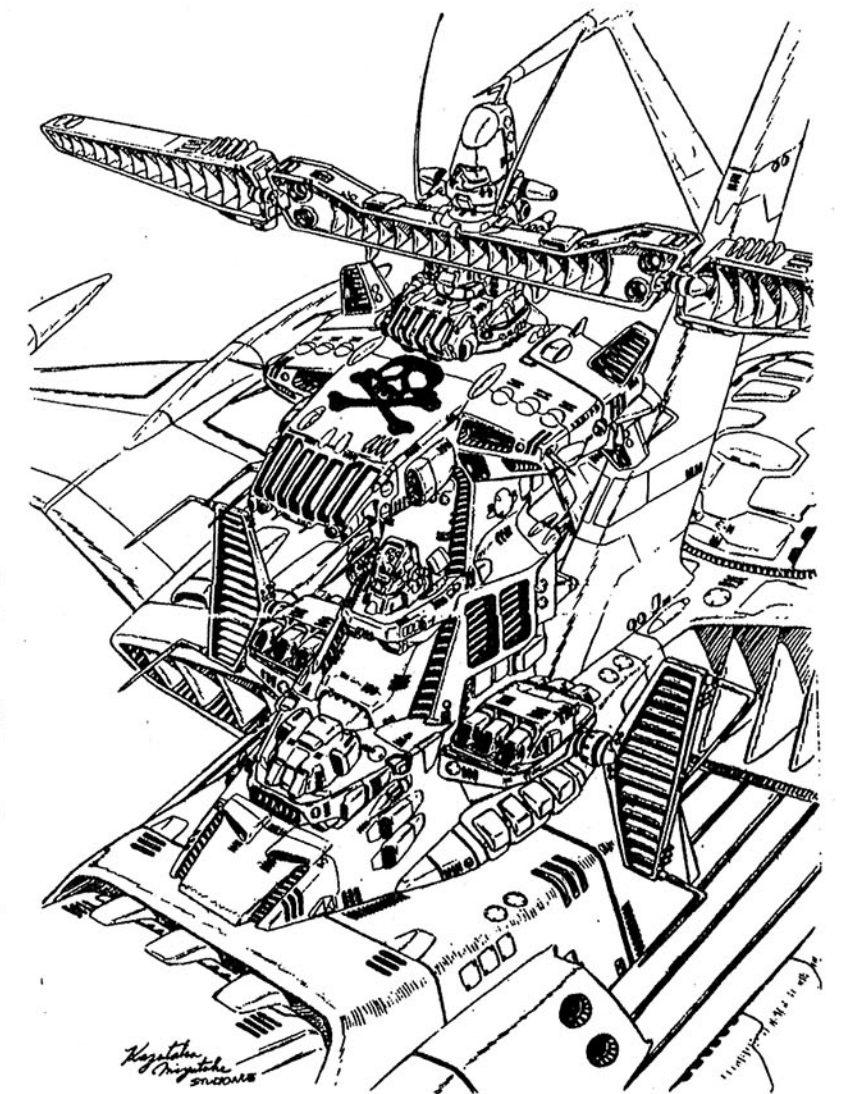

SPECIAL THANKS TO STEVE AND GORDON

QUEEN EMERALDAS

The vessel of free space-trader Emeraldas, it is a combination of airship and galleon in design, the armored upper segment containing engines and cargo space. The galleon houses the bridge and cabins and is lined with 16 particle beam cannons.

Emeraldas obtained the ship from the pirate Zonarana on planet Jula and crewed it entirely with robots.
Length: 338m

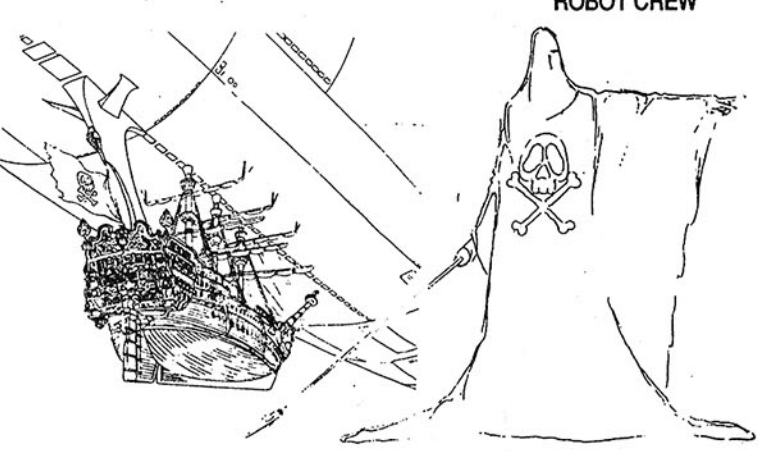
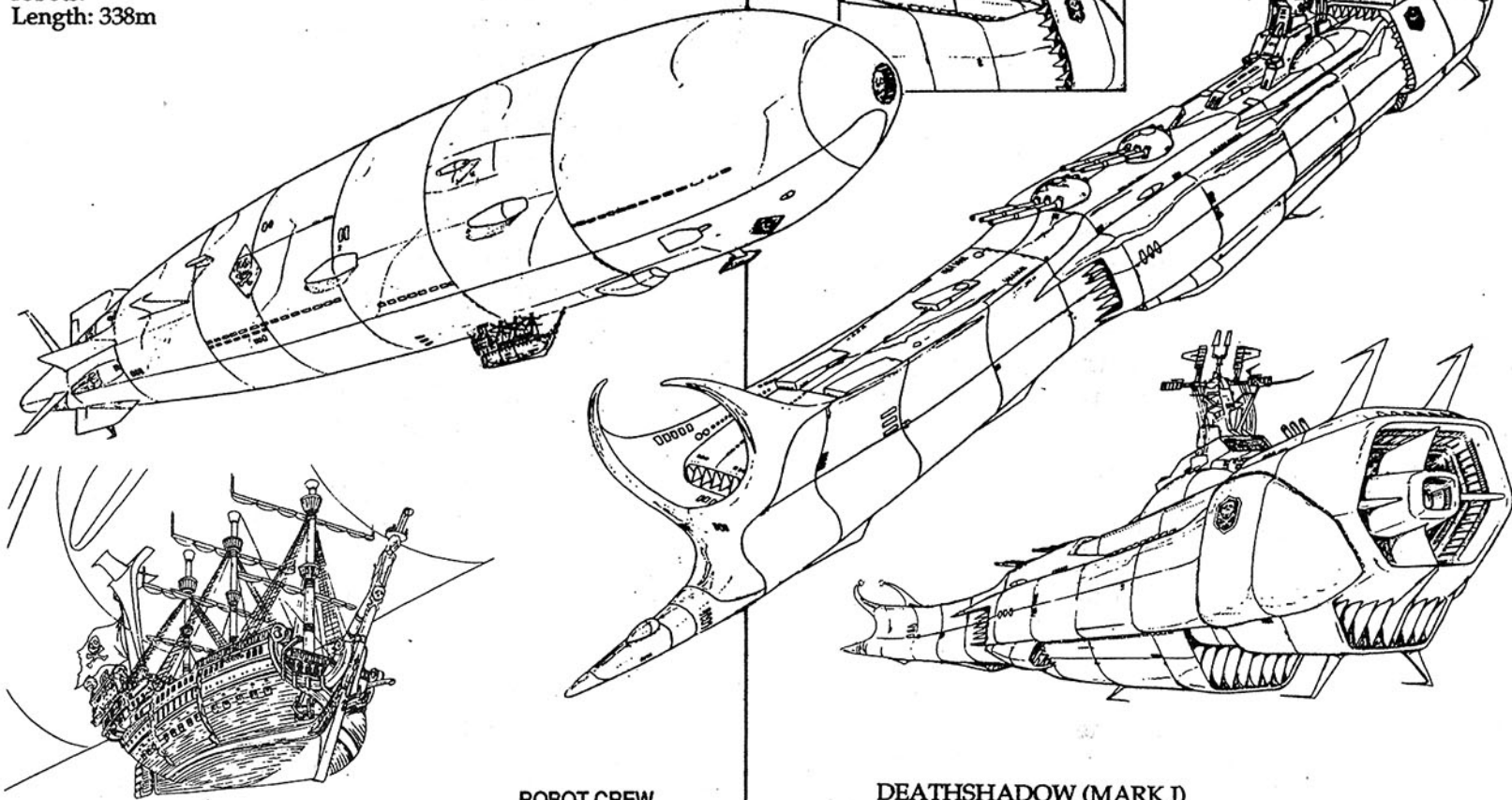

ROBOT CREW

DEATHSHADOW (MARK I)

The flagship of the Solar Federation Earth Fleet, which fought valiantly against the Illumidas only to be defeated in the battle of the Castlemain System with Harlock as the captain, after which time it was used to transport refugees and sported Harlock's pirate mark.

Length: 286m
Armament: 3 beam cannons
Multiple pulse cannons and torpedoes
Minimum crew 5, maximum capacity 2400.

ILLUMIDAS EMPIRE

Cold, cruel and ruthless, the green-skinned Illumidas have conquered and occupied hundreds of worlds, distinguishing themselves alongside the Mechanized Empire as a major galactic power. They are the ultimate racists and display a callous disregard for other life forms. The contaminative influence of rebel elements like Harlock and Tochio are the bane of the Illumidas, who prize the orderly running of their empire above all else.

HEAVY CRUISER

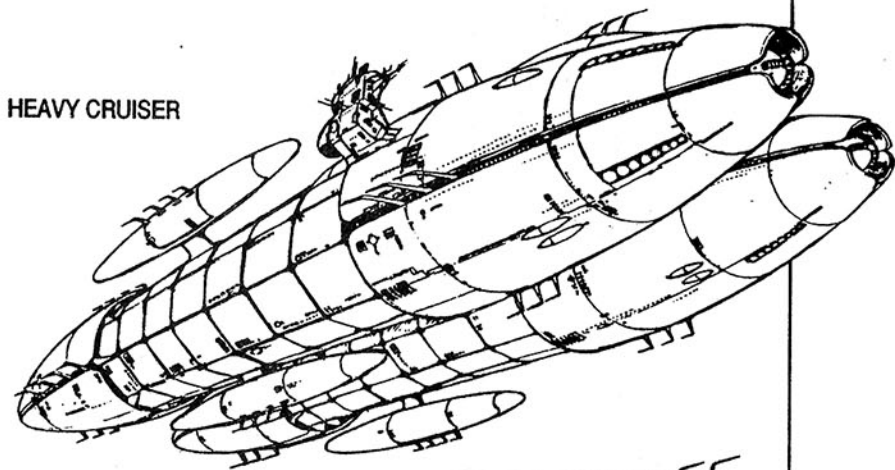

MID-RANGE CRUISER

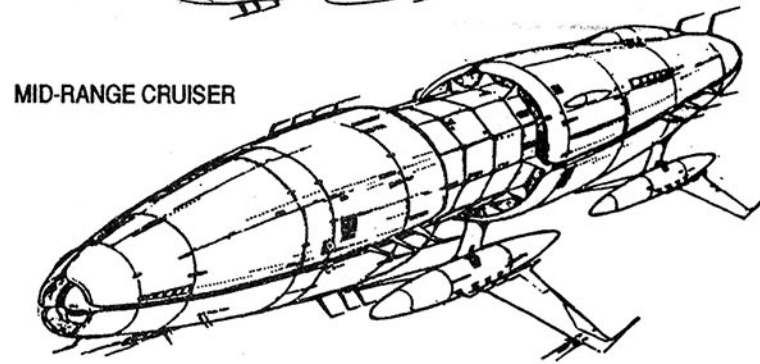

ILLUMIDAS FOOTSOLDIER

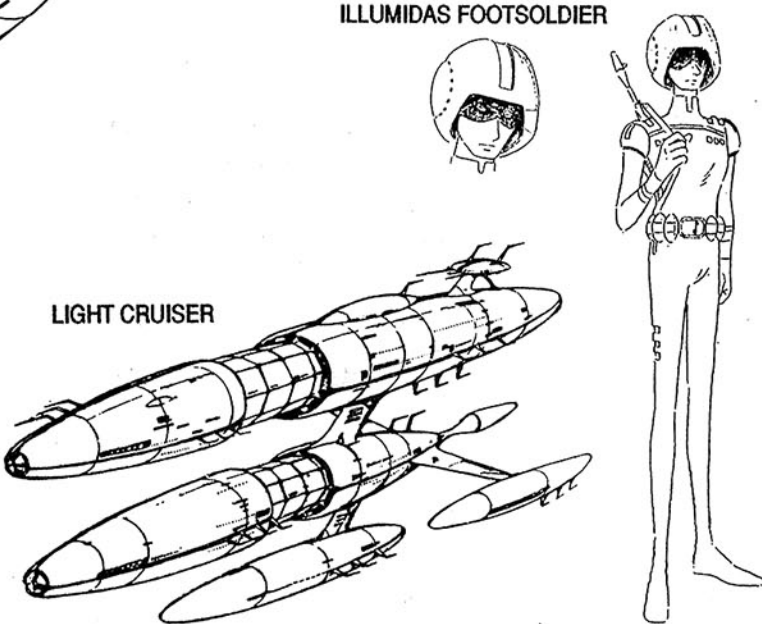

LIGHT CRUISER

MANGA AND MYTH: HARLOCK IN JAPAN

A man appears before a boy, beckoning him toward the ship flying a pirate's flag. This is how Harlock has always appeared to young men such as Tadashi and to the readers of his many manga adventures by Leiji Matsumoto. In a way, Matsumoto himself was that young man to whom Harlock beckoned, and they have been together ever since.

First designing the character as "Captain Kingston" in Junior High School, Matsumoto pursued a successful career in comics and brought the character back in a variety of guises, sometimes friend, sometimes enemy. But the strength of the character endured; even when placed in a supporting role, Harlock was always the most intriguing player.

Because Harlock has always been an outlaw, a stranger, and an exception to ordinary social life, he has always represented freedom in its purest form. His freedom is unlike any offered by society with the inherent limitations. He fights to protect his freedom and invites us to share it.

But there is a darker side to him as well. Balancing freedom is death, both the death he dispenses to his enemies and the death he carries himself. In many of his manga appearances, Harlock is near to dying, at which time he chooses to pass the mantle of freedom to a young man. The intrigue of the character lies in the contradiction of teaching boys to live for freedom while he is searching for a place to die.



An example of this in Matsumoto's classic 1970 manga, "Great Pirate Harlock", in which Harlock appears to exact vengeance on the Earth fleet and dies after turning his ship, the Deathshadow, over to a young man named Sado. Harlock also appeared in the manga version of *Space Battleship Yamato* before Susumu Kodai, destroying Emperor Desular while dying of radiation poisoning. Subsequently, we learn that Harlock was Kodai's older brother, who may very well have met a previous Harlock.

Graduating from manga to television tended to diffuse the intensity of this death-image, but this did not stop *Space Pirate Captain Harlock* from becoming a tremendously animated hit in 1977. Harlock subsequently appeared as a supporting character in Matsumoto's *Galaxy Express 999*. Like Will Eisner's *The Spirit*, the most effective use of the character was

as a catalyst, and the true impact of his actions was most noticeable in the people around him.

Finally, the feature film *My Youth In Arcadia* told the story of Harlock's origin, and sported what many have come to regard as the quintessential image of the character. This was followed by the short lived-lived TV series *Endless Road SSX*, which was chiefly written by other scriptwriters and favored a more traditional hero-image.

But the eternal mythology with which Matsumoto infused Captain Harlock has so strongly inhabited the character that it continues to defy attachment to single visual interpretation. The stories themselves defy any chronological categorization. In one form or another, Harlock will beckon us to his flag of freedom for a long time to come.

-Tim Eldred and Katsu Suzuki

TIMELINE OF HARLOCK IN MATSUMOTO'S WORK

- 1953: "Adventures" featuring Captain Kingston
- 1968: "Lightspeed Esper" with the enemy Dr. Harlock
- 1969: "Pilot 262" Harlock's facial scar first appears
- 1970: "Mrs. L Drifting Story" Harlock with eyepatch
"Great Pirate Harlock" first appearance of DEATHSHADOW
- 1971: "Dr. Devil's Horrible Brain Surgery"
- 1972: "Gun Frontier" Harlock meets Tochio
- 1973: "Short Sighted Human Anthology" Harlock with white hair
"Witch of Stanley" Phantom F. Harlock challenges the Owen Stanelly Mountains in his airplane ARCADIA
- 1974: "Goodbye Romantic Time" with Harlock wanna-be Akeno Kojiro
- 1975: "Story of Unrecoverable Time"
"Mechanized City"
"Birdman of Kilimanjaro"
"Spaceship Deathshadow"
"Emeraldas"
"The Cockpit" and "Immortal Arcadia" Harlock as a German WWII pilot
"Diver O"
- 1977: "Small Room in the Big Field"
"Space Pirate Captain Harlock" 42-episode TV series and manga
- 1978: "Space Pirate Captain Harlock/The Mystery of the ARCADIA" animated featurette
- 1979: "Galaxy Express 999" feature film
- 1980: "Galaxy Express 999" TV series, episodes 79-81
("Pirates of the Time Castle")
- 1981: "Adieu Galaxy Express 999" feature film
- 1982: "My Youth in ARCADIA" feature film
"Endless Road SSX" 22-episode TV series